



Name: AnM200xxxB07M

Features:

- Native Components
- Structure NPT+
- Low $V_{CE(sat)}$
- High short circuit capability
- Easy paralleling
- Positive temperature coefficient of $V_{CE(sat)}$
- Low C_{ies} , C_{oes} , C_{res}
- 100% control of the effect of double current
- Insulated base plate for heat dissipation
- Self-restraint on the short-circuit currents

Applications:

- AC Motor Control
- Motion/Servo Control
- UPS



HB	
HBE	
RC	
LC	

Type	V_{CE}	I_c	Package	Packaging
AnM200HBB07M	650V	200A	B – 62 mm	Box
AnM200HBEB07M				
AnM200LCB07M				
AnM200RCB07M				

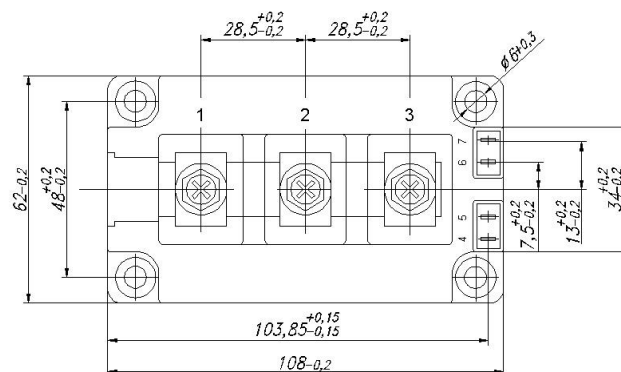
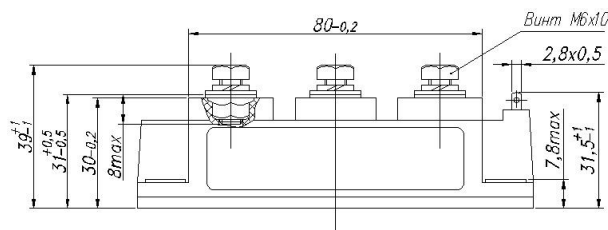



Table 1 – Absolute Maximum Rated Values

	Parameter		Units
IGBT			
V_{CES}	Collector-to-Emitter Voltage	1200	V
V_{GES}	Gate-to-Emitter Voltage	± 20	V
$I_C, T_C=25\text{ }^\circ\text{C}$	Collector Current	250	A
$I_{CM}, T_C=25\text{ }^\circ\text{C}$	Pulsed Collector Current	500	
$I_C, T_C=70\text{ }^\circ\text{C}$	Collector Current	200	
$I_{CM}, T_C=70\text{ }^\circ\text{C}$	Pulsed Collector Current	400	
$P_D, T_C=25\text{ }^\circ\text{C}$	Maximum Dissipation	820	W
Inverse diode			
$I_F, T_C=25\text{ }^\circ\text{C}$	Forward Current	200	A
$I_{FM}, T_C=25\text{ }^\circ\text{C}$	Pulsed Forward Current	400	
$I_F, T_C=70\text{ }^\circ\text{C}$	Forward Current	160	
$I_{FM}, T_C=70\text{ }^\circ\text{C}$	Pulsed Emitter Current	320	
Free-Wheeling diode			
$I_F, T_C=25\text{ }^\circ\text{C}$	Forward Current	200	A
$I_{FM}, T_C=25\text{ }^\circ\text{C}$	Pulsed Forward Current	400	
$I_F, T_C=70\text{ }^\circ\text{C}$	Forward Current	160	
$I_{FM}, T_C=70\text{ }^\circ\text{C}$	Pulsed Emitter Current	320	
T_j	Operating Temperature	-55 to +150	°C
T_{stg}	Storage Temperature	-55 to +125	
	Mounting Torque, M6	3.0 to 5.0	N * m
	Weight	450	g
V_{is}	Insulation Test Voltage ($t=1\text{ min.}$)	2500	Vrms

Table 2 – Thermal Resistance

Symbol	Parameter	Min	Max	Units	Test Conditions
R_{thJC}	Thermal Resistance, Junction-to-Case	–	0.15	°C/W	Per IGBT
R_{thJCD}	Thermal Resistance, Junction-to-Case	–	0.32		Per FWD



Table 3 – Electrical Characteristics @ $T_j=25\text{ °C}$ (unless otherwise specified)

Symbol	Parameter	Min.	Typ.	Max.	Units	Test Conditions
IGBT						
$V_{CE(sat)}$	Collector-to-Emitter Saturation Voltage	–	1.9	2.2	V	$V_{GE}=15\text{ V}$, $I_C=200\text{ A}$
		–	2.4	2.5		$V_{GE}=15\text{ V}$, $I_C=200\text{ A}$, $T_j=125\text{ °C}$
$V_{GE(th)}$	Gate Threshold Voltage	4.0	5.5	7.0	V	$V_{GE}=V_{GES}$, $I_C=5.0\text{ mA}$
I_{CES}	Zero Gate Voltage Collector Current	–	0.01	0.5	mA	$V_{CE}=650\text{ V}$, $V_{GE}=0\text{ V}$
		–	0.5	2.0		$V_{CE}=650\text{ V}$, $V_{GE}=0\text{ V}$, $T_j=125\text{ °C}$
$I_{GES(F)}$	Gate-to-Source Leakage Forward	–	10	100	nA	$V_{GE}=20\text{ V}$
		–	20	150		$V_{GE}=20\text{ V}$, $T_j=125\text{ °C}$
$I_{GES(R)}$	Gate-to-Source Leakage Reverse	–100	–10	–	nA	$V_{GE}=-20\text{ V}$
		–150	–20	–		$V_{GE}=-20\text{ V}$, $T_j=125\text{ °C}$
C_{ies}	Input Capacitance	–	tbd	–	nF	$V_{GE}=0\text{ V}$, $V_{CE}=25\text{ V}$, $f=1\text{ MHz}$
C_{oes}	Output Capacitance	–	tbd	–		
C_{res}	Reverse Transfer Capacitance	–	tbd	–		
$t_{d(on)}$	Turn-On Delay Time	–	tbd	–	ns	$V_{CC}=350\text{ V}$, $I_C=200\text{ A}$, $V_{GE}=\pm 15\text{ V}$, $R_G=10\text{ }\Omega$, $T_j=125\text{ °C}$, Inductive Load
t_r	Rise Time	–	tbd	–		
$t_{d(off)}$	Turn-Off Delay Time	–	tbd	–		
t_f	Fall Time	–	tbd	–		
E_{on}	Turn-On Energy	–	tbd	–	mJ	$V_{CC}=350\text{ V}$, $I_C=200\text{ A}$, $V_{GE}=\pm 15\text{ V}$, $R_G=10\text{ }\Omega$, $T_j=125\text{ °C}$, Inductive Load
E_{off}	Turn-Off Energy	–	tbd	–		
E_{tot}	Total Energy	–	tbd	–		
I_{sc}	Short circuit collector current	–	600	–	A	$t_p \leq 10\text{ }\mu\text{sec}$, $V_{GE} \leq 15\text{ V}$, $R_G=10\text{ }\Omega$, $T_j=125\text{ °C}$, $V_{CC}=400\text{ V}$, $V_{CEmax}=V_{CES}-L_{sCE} \cdot di/dt$

**Inverse and Free-Wheeling Diode**

V_F	Forward Voltage	–	1.9	2.0	V	$I_F=200\text{ A}, V_{GE}=0\text{ V}$
I_{rrm}	Maximum Reverse Recovery Current	–	120	–	A	$I_F=200\text{ A},$ $di_F/dt=0.5\text{ A/ns},$ $V_{GE}=0\text{ V},$ $T_j=25\text{ °C}$
t_{rr}	Diode Reverse Recovery Time	–	200	300	ns	
Q_{rr}	Diode Reverse Recovery Charge	–	25	–	μC	

Precious metal content into 1000 pieces:

Gold _____ g;

Silver _____g.



Table 4 – Revision history

Date	Revision	Changes
03-Oct-2016	1	Complete version. Preliminary.